

SF₆ GAS DENSITY MONITORS FOR BOTH INDOOR AND OUTDOOR INSTALLATIONS

MODEL: SPG-200-A (Air-Filled), SPG-200-S (Silicone-Filled)

SPECIFICATIONS

These instruments are manufactured to monitor the electrical operations on hermetically sealed systems containing Sulphur Hexafluoride gas (SF₆). The indication and electrical operations are calibrated to the gas density (isochore) based on the changes of pressure and temperature relations. The SPG-100 is suitable for both indoor and outdoor installations to meet most of the applications demanded on market.

The oil filled executions are particularly suitable for installations when vibrations are apparent.

Switchgear is hermetically sealed and filled with SF₆ gas. The material properties of SF₆ gas which are essential for such applications, such as the electrical disruptive strength or the electric light arc quenching capability, are dependent on the density of the SF₆ gas. The required SF₆ gas density depends on the respective application. This means that the functional safety of the entire system is strongly dependent on the density of SF₆ gas which is why it must be monitored.



SPG-200-A

GENERAL CHARACTERISTICS

NOMINAL DIAMETERS (mm)

100 (DN100)

ACCURACY

±1,0% at +20°C of Ambient Temp.
±2,5% within the Ambient Temperature
Ranges between -20...60°C related to the calibrated pressure of the reference isochore

POINTER

Black Aluminum

COMMUNICATION INTERFACE

RS-485 Asynchronous Mode
0-5 or 0-10 VDC Eletrical/Analog Output

RING

Bayonet Lock, Stainless Steel AISI 304 with Antitampering Sealing

GAS SEAL

Leakage Rate $\leq 1 \cdot 10^{-8}$ mbar·l/s (Helium Leak Test with Mass Spectrometer)

RANGES

Vacuum & Compound Gauges from 1,6 to 25 bar

CALIBRATION PRESSURE

Refer to Order Specifications

ALARM CONTACTS

Non-Adjustable Contacts with Antitampering Sealing:
-On Air with Magnetic Block (80%Ag-20%Ni, 10µm Gold-Plated)
-Maximum Contact Rating with Non-Inductive Ohmic Load, Filled: 20W / 20VA, Maximum 1A
-Contact Available: Up to 3 Snap Action Non Inductive Contacts

WINDOW

Safety Glass

MOVEMENT

Stainless Steel with Bimetallic Temperature Compensator

DIAL

White Aluminum with Black Markings and Colors Sectors as per Customer's Specification

WEIGHT

1.2 KG

TECHNICAL FEATURES

AMBIENT TEMPERATURE

-20...+60°C

CASE

Fully Welded Stainless Steel AISI 304
Filled with Silicon Dielectric Oil
Leakage Rate $\leq 1 \cdot 10^{-5}$ mbar·l/s (Helium Leak Test with Mass Spectrometer)
Hermetically Sealed Design

PROTECTION DEGREE

IP 65 as per EN 60 529 / IEC 529

STORAGE TEMPERATURE

-50...+60°C

PROCESS CONNECTION

Fully Welded Stainless Steel AISI 316
M20 x 1,5
G½B Thread (EN 837), SW22

MEASURING ELEMENT

Welded Stainless Steel AISI 316
Leakage Rate $\leq 1 \cdot 10^{-8}$ mbar·l/s (Helium Leak Test)

ELECTRICAL CONNECTION

Junction Box with Cable Gland
M20 x 1,5 – PG 13,5

INSTALLATION LOCATIONS

Indoor and Outdoor Installations

HIGH VOLTAGE TEST

2 kV, 50Hz, 1s (Internal Circuit)

OPTIONS & ACCESSORIES

Junction Box on the Left
Contact Adjustment Adjustable
Removable Junction Box – PG13,5

DIMENSIONS (MM)

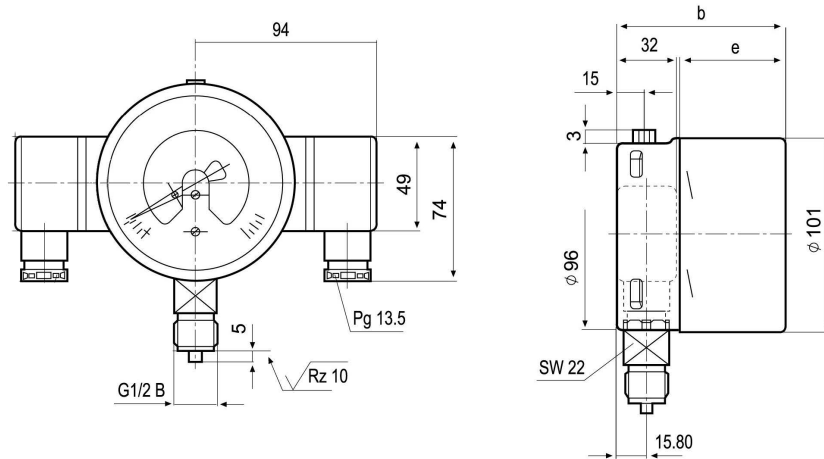

DIMENSIONS (MM)	b	e
Single/Double Contacts with Isolating Layers	96	63
Triple Contacts with Isolating Layers	96	63

POWER RATINGS: MAXIMUM CONTACT RATING

MAXIMUM CONTACT RATING WITH NON INDUCTIVE (OHMIC LOAD)	MAGNETIC SNAP-ACTION CONTACT	
	GAS FILLED GAUGES	LIQUID FILLED GAUGES
Maximum Voltage	250 V	250 V
Current Ratings:		
Make Rating:	1,0 A	1,0 A
Break Rating:	1,0 A	1,0 A
Continuous Load	0,6 A	0,6 A
Maximum Load	30 W 50 VA	20 W 20 VA

RECOMMENDED CONTACT RATINGS

VOLTAGE (DIN IEC 38) DC / AC	MAGNETIC SNAP-ACTION CONTACT					
	GAS FILLED GAUGES			LIQUID FILLED GAUGES		
	Ohmic Load		Inductive Load cosφ>0,7	Ohmic Load		Inductive Load cosφ>0,7
V	DC mA	AC mA	mA	DC mA	AC mA	mA
230	100	120	65	65	90	40
110	200	240	130	130	180	85
48	300	450	200	190	330	130
24	400	600	250	250	450	150

Note: Please refer to the user’s manual for detailed maximum power ratings and recommendations.